

FLUONICS Lined Products

Series FDI2

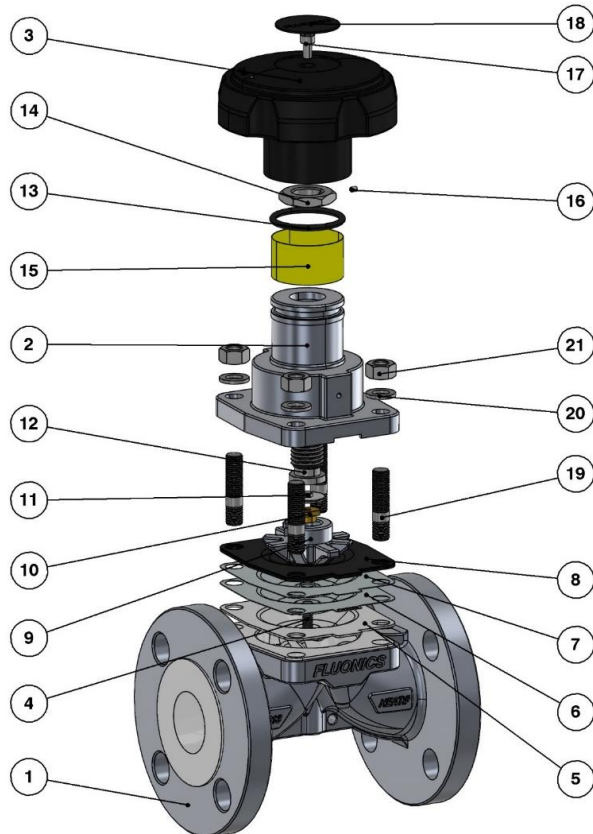

STRUCTURE & SPECIFICATIONS

No.	PART NAME	MATERIAL	No.	PART NAME	MATERIAL
1	BODY	WCB/CF8 with PFA	12	SPINDLE	STAINLESS STEEL
2	BONNET	CF8	13	O-RING	VITON
3	HANDWHEEL	PA66+G/F	14	STOPPING NUT	STAINLESS STEEL
4	DIAPHRAGM SHEET BOLT	SUS316/ Ti-Pd(*Option)	15	INDICATOR	PLASTIC
5	DIAPHRAGM SHEET	M-PTFE	16	STOPPING NUT SET SCREW	STAINLESS STEEL
6	DIAPHRAGM FILM	PFA(*Option)	17	HANDWHEEL SET SCREW	STAINLESS STEEL
7	DIAPHRAGM FILM	PTFE(*Option)	18	HANDWHEEL STICKER	PET FLIM
8	DIAPHRAGM RUBBER	EPDM/VITON (*Option)	19	STUD BOLT	STAINLESS STEEL
9	COMPRESSOR	CF8	20	WASHER	STAINLESS STEEL
10	FLOATING NUT	BRASS	21	HEX NUT	STAINLESS STEEL
11	SPINDLE BEARING	POM			