

FLUONICS Lined Products

Series FPL2

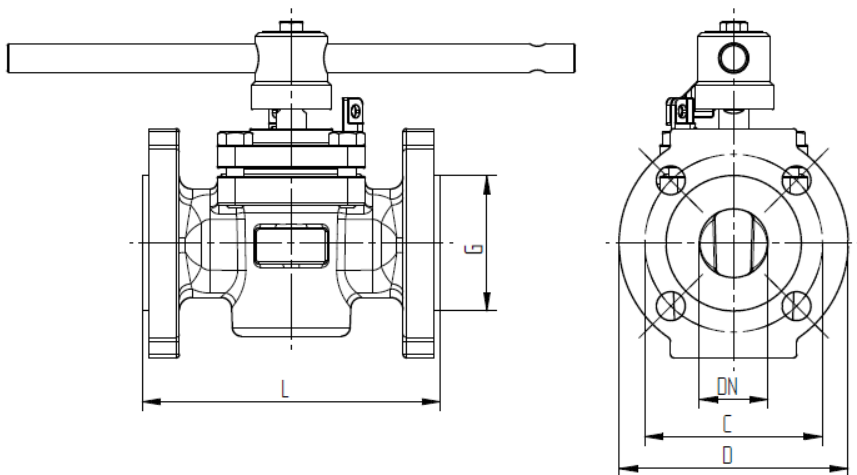

Pressure-Temperature Chart

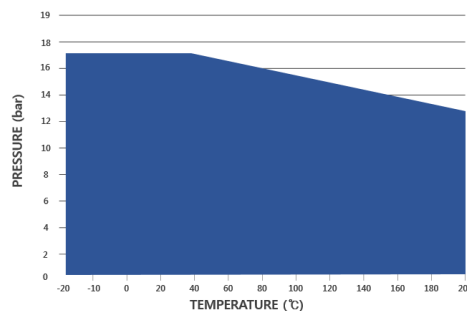

SIZE		Operating Torque(N·m)	Cv
½"	15A	30	10
¾"	20A	30	12
1"	25A	45	40
1½"	40A	60	89
2"	50A	110	172
3"	80A	140	290
4"	100A	250	530
6"	150A	600	1060
8"	200A	1800	1580

ANSI 150 LBS

SIZE	DN	L	D	C	G	N-d
½"	13	108	89	60.5	35	4-16
¾"	18	117	99	70	43	4-16
1"	25	127	108	79.5	56	4-16
1½"	38	165	127	98.5	75	4-16
2"	50	178	155	120.5	94	4-19
3"	76	203	190	152.5	125	4-19
4"	100	229	229	190.5	150	8-19
6"	150	267	280	241	212	8-23
8"	200	292	343	298.5	260	8-22

JIS 10K

SIZE	DN	L	D	C	G	N-d
15A	13	108	95	70	35	4-15
20A	18	117	100	75	54	4-15
25A	25	127	125	90	64	4-19
40A	38	165	140	105	79	4-19
50A	50	178	155	120	94	4-19
80A	76	203	190	150	125	8-19
100A	100	229	229	175	150	8-19
150A	150	267	280	241	212	8-23
200A	200	292	343	290	260	12-23